

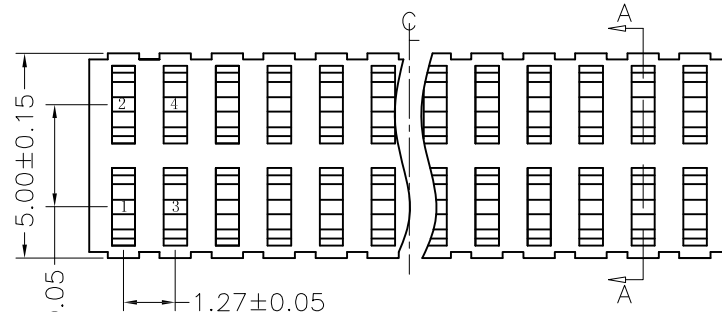

Recommended P.C.B Layout(Top Side)
(PCB BOARD TOLERANCE±0.05)

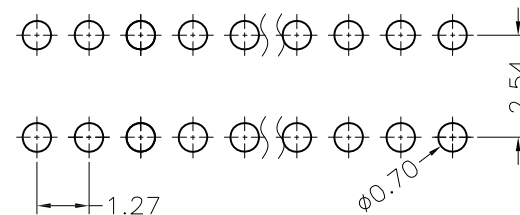

PART NUMBER CODING

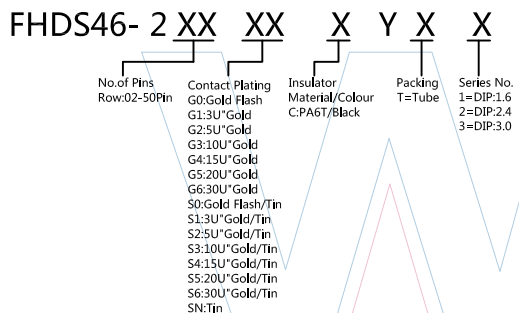

TITEL	PART NO.
A=1. 60	FHCS46-2XXXXXXYX1
A=2. 40	FHCS46-2XXXXXXYX2
A=3. 00	FHCS46-2XXXXXXYX3

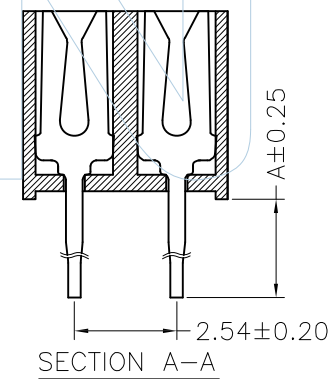
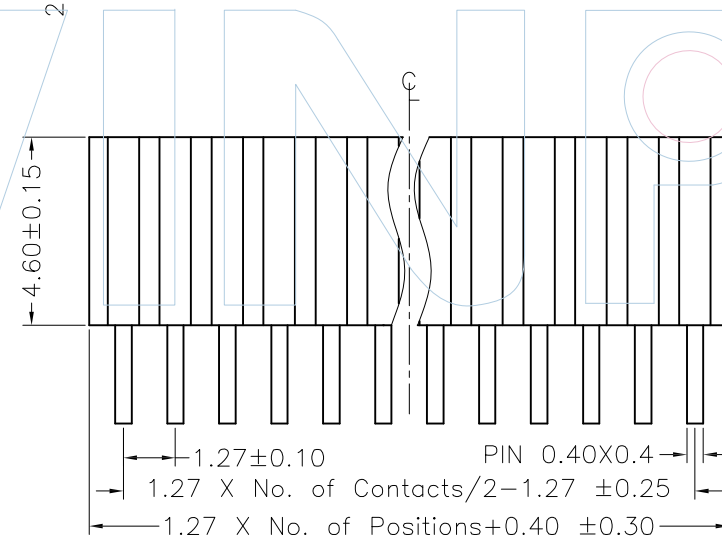

Tel:+86 769 82581808 FAX:+86 769 81766192
E-Mail:winpin@win-pin.com Http:www.win-pin.com

PART NO: FHDS46-2XXXXXXYX

TITLE: FH1.27*2.54mm Dual Female 180° H=4.6mm

NOTES:
Current Rating:1.0AMP
Contact Resistance:20mΩ Max
Insulation Resistance:1000MΩ Min
Withstand Voltage:500V AC/Minute
Operation Temperature:-55°C to +125°C

Contact Material:Phosphor Bronze
Contact Plating:Au over Ni
Insulator Material:Polyester (UL94V-0)
Standard:PA6T+30%GF Black

UNLESS OTHERWISE SPECIFIED DIMENSIONS ARE IN METRIC TOLERANCES ARE:
DECIMALS Angle
X.X:±0.40 ± 3°
X.XX:±0.25
X.XXX:±0.15

SCALE	1:1
UNIT	MM
PROJ.	
SHEET	

REV	DATE	MODIFICATION DESCRIPTION	DRAW	CHANGE	APPROVE
A0	2015/06/25	NEW	Huan.Tan		Huan.Tan